

As⁺³ Low Range II As⁺⁵ QUICK™ Rapid Arsenic Test Kit

Kit Part Number: 481301
50 Tests

Instruction Booklet	Page
About Kit #481301.....	2
Test Procedure.....	3
Suggestions for Best Accuracy.....	4
Arsenic Scan Instructions.....	5
Material Safety Data Sheets.....	6-7
Letter from the Kit Inventor.....	8



Information on the performance characteristics of this kit can be found at www.epa.gov/etv/verifications/verification-index.html, or call ITS at 803-329-9712 for a copy of the ETV verification report. The use of the ETV® Name or Logo does not imply approval or certification of this product nor does it make any explicit or implied warranties or guarantees as to product performance.

FOR BEST RESULTS, FOLLOW KIT INSTRUCTIONS.

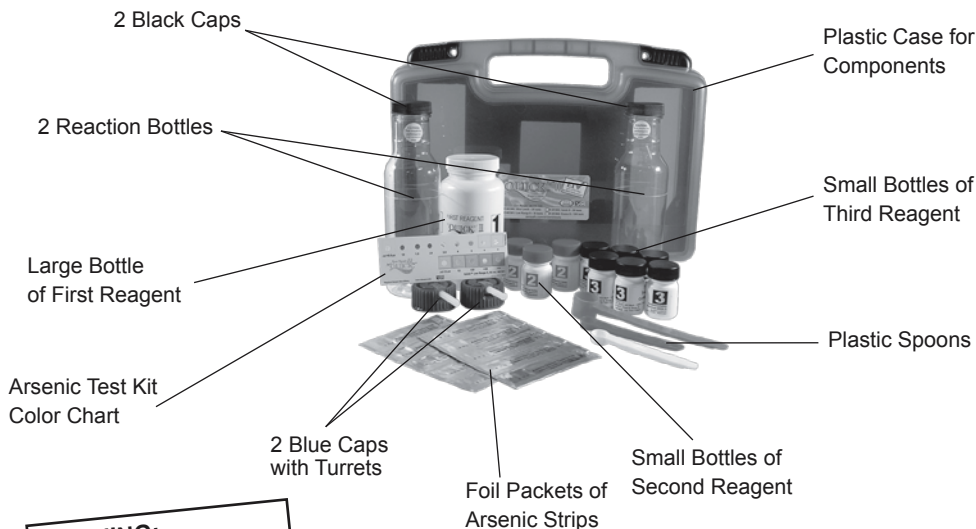

WARNING:
Hydrogen and Arsine gases are generated during the test. Work in a well-ventilated area away from open flames and other sources of ignition. Review the Material Safety Data Sheet before handling any chemicals.

Industrial Test Systems, Inc.
1875 Langston Street, Rock Hill, SC 29730 USA
Phone: (800) 861-9712, (803) 329-9712, **Fax:** (803) 329-9743
eMail: its@sensafe.com, **International:** www.ITSExport@sensafe.com
Web: www.sensafe.com



ITS Europe, LTD
The UK Centre for Homeland Security
Building 7, Chilmark
Salisbury, Wiltshire SP3 5DU, UK
Phone: +44 (0)1722 717911, **Fax:** +44 (0) 1722 717941

481301-INST
Revision: 01/06/12

ABOUT KIT # 481301:

This test detects soluble inorganic Arsenic (As^{+3} and As^{+5})



Part Number: 481301, 50 Tests

This Arsenic Test Kit provides a safe, simple, and precise way to test for Arsenic from 1 to 10 $\mu\text{g/L}$. For accurate results when Arsenic value is above 10 $\mu\text{g/L}$, perform a dilution of the water sample so that the value will read below 10 $\mu\text{g/L}$. Follow the instructions carefully to get reliable results. All components are supplied in the kit except for a timer and thermometer. This test tolerates up to 2.0 mg/L Hydrogen Sulfide without interference. No interference was found for this test kit for Antimony up to 0.5mg/L. No interference from Iron or Sulfate was found. Higher levels of Hydrogen Sulfide can be corrected for by diluting (only where sensitivity needs are not compromised). There were no interferences from other components typically found in tap water. It is recommended that the water sample be 22°C - 28°C. For reference, record the temperature at which the sample was run. Use kit within the shelf life as marked.

Kit Components:

- 2 Reaction Bottles, clear PVC, with 250mL line
- 2 Blue Caps, with white turret, for holding testing pad
- 3 Plastic Spoons (one large pink spoon for First Reagent; one small red spoon for Second Reagent; and one small white spoon for Third Reagent)
- 1 Large Bottle of First Reagent (350gm)
- 3 Small Bottles of Second Reagent (26gm ea.)
- 6 Small Bottles of Third Reagent (28gm ea.)
- 50 Packets of Arsenic Testing pad strips - **Caution:** Each test pad contains about 1 mg Mercuric Bromide ($HgBr_2$)
- This Instruction Booklet with MSDS
- Plastic Bag for Used Test Strips (not pictured below)
- 2 Black Caps for mixing
- Plastic Case for Components
- Easy-Read™ Color Chart

About the Patented Reaction (Modified Gutzeit method):

Inorganic Arsenic compounds in the water sample are converted to Arsine (AsH_3) gas by the reaction of Zinc Dust and Tartaric Acid. Ferrous and Nickel salts have been added to accelerate this reaction. The Arsine reacts with the Mercuric Bromide on the test strip to form mixed Mercury halogens (such as AsH_2HgBr) that appear with a color change from white to yellow or brown. Potassium Peroxymonosulfate (second reagent) is added to oxidize Hydrogen Sulfide to Sulfate.

PRECAUTIONS: Hydrogen gas and Arsine gas are generated during the reaction. Work in a well-ventilated area away from fire and other sources of ignition. All reagents are unsuitable for human consumption and must be kept away from children and pets.

US Patent # 6696300

ATTENTION: Your Arsenic results will be low if step 5 in the Test Procedure is not followed carefully.

When you position the testing pad over the orifice, you must press down the turret handle very firmly over the testing pad to securely lock the testing pad into position. If the cap is not firmly formed around the testing pad, arsine gas will bypass the testing pad, which results in lower arsenic levels.

One method of assuring a properly seated testing pad is to use the round end of a pen to apply pressure to the turret (Image 1).



Image 1



Image 2

Another technique is to simultaneously press on the red turret and the turret handle to properly seat the turret into the testing pad (Image 2).

WARNING: Hydrogen and Arsine gases are generated during the test. Work in a well-ventilated area away from open flames and other sources of ignition. Review the Material Safety Data Sheet before handling any chemicals.

For better accuracy, we recommend running the test in duplicate for each water sample.



FOLLOW KIT INSTRUCTIONS CLOSELY.
Part Number: 481301, 50 Tests

Test Procedure:

(See Instruction Sticker in plastic case cover for visual help.)

1. For best results, the water temperature should be between 22°C to 28°C. Use a thermometer to verify the temperature of the sample.
2. To the Reaction Bottle, slowly add the water sample to the marked line on the bottle (250mL).
3. Add 1 level pink spoon of First Reagent (Quick™ II) to the Reaction Bottle. Cap securely with the black cap and shake vigorously for **15 seconds**.
4. Uncap the Reaction Bottle and add 1 level red spoon of the Second Reagent. Recap securely with the black cap and shake vigorously for **15 seconds**. Allow the sample to sit for 2 minutes to minimize Sulfide interference.
5. **While the test is incubating for 2 minutes**, prepare the **turret cap** as follows (NOTE: The cap and turret must be dry. If the testing pad becomes wet results will be compromised):
 - a) Open the packet and carefully remove the strip. While handling the strip avoid touching the Mercuric Bromide testing pad at one end of the testing strip.
 - b) Position either side of the testing pad over the orifice (Figure 1) and press down the turret handle over the pad until it locks into position on the cap. Make certain the red turret with handle is fully closed (as illustrated in Figure 2). The red turret should be pressed level with the top of the cap to ensure all gas passes through the testing pad during the **10 minute** wait. To confirm that the testing pad completely covers the hole in the cap, visually inspect the orifice from under the cap. The **turret cap** is now ready for use in Step 7.
6. Uncap the Reaction Bottle and add 1 level white spoon of the Third Reagent. Recap securely with the black cap and shake vigorously for **5 seconds**.
7. Remove the black cap from the Reaction Bottle and recap securely using the **turret cap** within **20 seconds**. As you screw on the **turret cap**, be careful not to splash the water or reagents on the testing pad. It is important that the testing pad remains dry during the test. Place the bottle in a well-ventilated area where it will not be disturbed. You should notice numerous small hydrogen gas bubbles generating from the Tartaric Acid and Zinc Dust Reagents.
8. **Start the timer and wait for 10 minutes**. Reaction generates small hydrogen gas bubbles.
9. **After waiting 10 minutes** (but no longer than 12 minutes), pull the turret up. Carefully remove the test strip with the testing pad. Flatten the testing pad, if necessary, by gently pressing it between two clean pieces of paper. Use the Color Chart (Quick™ Low Range II) and match the color of the exposed side of the testing pad **within the next 2 minutes** (colors oxidize when exposed to light). For best color matching use natural daylight, but do not use direct sunlight. The color can be preserved for a short time by returning the testing pad to the packet and keeping it out of light. If using the **Quick™ Scan** Test Pad Reader, follow the meter's instructions.
10. Record your result.

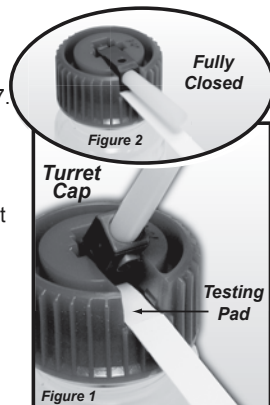

(Mercuric Bromide strips (Arsenic test strips) will not react with arsine gas if they are wet!)

NOTE: If your Arsenic Level is above 10ppb, retest with a 1 to 2 dilution; above 16ppb, retest with a 1 to 3 dilution; above 24ppb, retest with a 1 to 4 dilution, etc... This should improve accuracy of Arsenic detection for this kit. Use Arsenic-free water for dilution(s). When you record your result, be sure to multiply by the dilution factor to determine the true Arsenic value.

ATTENTION: Soon after testing is completed, decant liquid from the bottle down a drain that is not used for food preparation and flush with water. See comment #4 on page 4. Wet Zinc should be collected and disposed of according to local regulations. Rinse the bottle and the cap with clean water. Shake off any excess water. Do not rinse turret cap. It is best to dry turret cap with a soft tissue or paper towel, especially if you plan to run the next test immediately. Store the used strips in the plastic bag marked "Used Mercuric Bromide (HgBr₂) Test Strips". Keep the used strips inaccessible to children and pets, and dispose according to local environmental regulations.

INSTRUCTIONS FOR BEST ACCURACY

1. To gain confidence in using this test kit for unknown samples, it is highly recommended that you use the kit on a sample with a known inorganic Arsenic concentration value, or with a sample that has been prepared using an Arsenic standard. By making a “practice run” of the test, you will familiarize yourself with all of the procedures necessary to ensure accurate testing results. Additionally, you will have the opportunity to become familiar with the process of color matching, which will help to ensure accurate test results. ITS suggests the test be run in duplicate for better accuracy.
2. The water sample must not be preserved with Nitric Acid or any other preservation method. Small amounts of strong acids will interfere with the test results; and therefore it is best that the water sample be freshly drawn and run within 24 hours. Some water samples held for over 24 hours may read low. The water sample should not contain any significant amount of buffers. If you are planning to send a duplicate sample for ICP laboratory verification, follow preservation requirements for that sample only.
3. The water and ambient temperature are very important to ensure accurate results. As an example, a water temperature of 15°C can result in the color development on the testing pad to be lighter than the actual Arsenic concentration in the tested sample (a false low reading occurs). When the water is cold, warm water sample to 22°C to 28°C before testing (using a microwave is acceptable). If the water temperature is above 28°C your result may read low (accelerator chemistry reacts too fast). Consideration must also be made for the air temperature when running the test. Best results are from 22°C to 28°C (water and air). The color chart and Arsenic Scan chart are calibrated at 24°C.
4. After the test has been run, try to rinse out the reaction bottle with clean tap water as soon as possible. When the reaction chemicals are allowed to sit in the reaction bottle after the reaction time, the zinc may begin to adhere to the bottom of the bottle. When this occurs, you may need to clean the reaction bottle with a bottlebrush. Another method for zinc removal is to use a 20% Hydrochloric Acid (reusable) rinse. Be sure to rinse the reaction bottle with clean tap water before running the next test.
5. When matching your test strip pad with the colors on the Easy-Read™ color chart, it may be helpful to find a color that is clearly lighter than the test strip pad and make note of it (as an example, we will use a value of 1.5 ppb). Next, find a color that is clearly darker than the test strip pad (as an example, we will use a value of 3 ppb). By defining a lowest and highest possible value range we can assume that the correct color match is 2.0 ppb. If the 2.0 ppb color matches, then you have determined your Arsenic level. In some cases, an exact color match will not be available. Following these easy steps can make color matching more precise. Careful color matching will assure the best possible result.
6. Levels of Hydrogen Sulfide above 2 mg/L can interfere with this test, resulting in elevated Arsenic readings. Our test kit will eliminate up to 2 mg/L of Sulfide interference. To overcome Hydrogen Sulfide levels above 2 mg/L, allow the water sample to sit at room temperature, uncovered and exposed to air for 8 hours (about 50% of the H₂S gas dissipates for every 8 hours).
Industrial Test Systems, Inc. sells Hydrogen Sulfide detection kits (part # 481197-20) for quick, accurate verification of this interfering ion. The test kit detects levels of 0.3, 0.5, 1.0, and 2.0 mg/L (ppm). The Hydrogen Sulfide test kit contains all components necessary to run the test, and is economically priced at \$15.99 for 30 tests.
7. Do not use components from other kits. Interchanging components may result in inaccurate results since each kit is Quality Control released for accuracy with its given components. Some conditions can result in getting an incorrect reading: the presence of Hydrogen Sulfide above 2ppm; color matching in poor lighting conditions; color blindness of operator; and sample temperatures that are high or low.
8. If you have any questions or comments, please feel free to contact our R&D Department at 1-803-329-0162 ext 211 or by email at: its@sensafe.com.
9. Record your results and details for future reference.

Sample No.	1	2	3	4	5
Location					
Date					
Result					

QUICK™ ARSENIC SCAN INSTRUCTIONS (INSTRUMENT SOLD SEPARATELY) FOR USE WITH ARSENIC Quick™ TEST KIT:

Instrument Components:

1. Quick™ Arsenic Scan Unit (R710 Color Reflection Densitometer, part number 481305)
2. Operation Manual (109 page book)
3. Calibration Reference Card
4. 18 Month Limited Warranty and Registration Card
5. AC Adapter (110VAC)
6. Carrying Case
7. White Opaque Plastic Card (2 3/8" x 7")
8. Conversion Table for the Following Arsenic Test Kits:
Arsenic Quick™ Test Kit



Locate the ridged, black latch
The measurement shoe is now

1. Instrument setup for Arsenic measurement:

- a. Remove the instrument from the case and turn the instrument over with the bottom facing up. between the two (2) screws near the round end of the measurement shoe. Slide it forward. unlocked, and will lift up by spring action from the body of the instrument.
- b. Locate the "OFF/ON" switch at the square end of the instrument where the data port and DC 9V connector ports are located. Gently slide the switch to "ON".
- c. Turn the instrument upright so that the LCD screen and six soft keys (3 black buttons, menu, exit, help) are facing upward.
- d. Depress once any one of the six soft keys on top of the unit. The LCD display will turn on.
- e. The instrument is now ready to make density measurements.

Notes:

- a. The instrument is calibrated, and ready for use when received.
- b. The AC adapter (supplied) may be used while performing color density measurements. Be sure the power switch is "OFF" before connecting the adapter to prevent any surge in power.
- c. When the unit will stand unused for a long period of time slide the power switch to "OFF".
- d. Typically, over 100 measurements can be made when using the battery pack only.

2. Strip measurement:

- a. Run the test sample according to the arsenic kit instructions.
- b. Read the strip with the Quick™ Arsenic Scan instrument within 30 seconds of completing the test.
 - i. Place the reacted strip with colored test pad facing upward on the white opaque plastic card (2 3/8" x 7"). It is very important that the white opaque plastic card provided (or a white substance) is placed under the reacted strip for accurate measuring.
 - ii. Position the target circle of the base shoe over the color pad so that the pad is centered in the black outlined circle (as illustrated).
 - iii. Press the body of the instrument down until the optical head is in contact with the target circle. The message "Measuring..." will appear in the LCD. A "Y" and a number next to the "Y" will appear in the LCD (For example, Y = 0.19 indicates a yellow color density of 0.19).
 - iv. Use the number in the LCD (in the example 0.19) and compare with the Data Table provided to determine the concentration of arsenic in the sample. Be sure that you are using the appropriate Data Table for your test kit. 0.19 equals 20 µg/L or ppb Arsenic.
 - v. Record the "Y" value and the concentration of Arsenic from the appropriate Data Table for future reference. Note: Use of the Quick™ Arsenic Scan unit will yield more precise results when compared to using the Easy-Read™ color chart for color matching determinations.

3. Calibration of Instrument:

See details on pages 34-40 in the Color Reflection Densitometer Operation Manual. It is recommended that "Quick Cal" (pages 39-40) be performed weekly. It is also recommended that "Standard Calibration" (steps 4, 5, & 8 in the manual) be performed when "Quick Cal" results are not within the allowed +/- variance of the "Y" values (White, Black, & Solid {Yellow}) listed in the reference table below:

Step 1: White	Step 2: Black	Step 3: Solid (Yellow)
Y value +/- 0.01	Y value +/- 0.06	Y value +/- 0.03

The Conversion Table below is valid for (Zinc) Reagent 3 lot 9035.

**Note: For best accuracy dilute and retest samples with scan values above 0.57

Arsenic Scan Conversion Table for Arsenic Quick™ Low Range Kit Part # 481301													
Match the instrument reading to the corresponding As level (in ppb) as found in the table below:										"Ihara (Y) Reading" = Yellow density value			
Ihara (Y) Reading	As Level (ppb)	Ihara (Y) Reading	As Level (ppb)	Ihara (Y) Reading	As Level (ppb)	Ihara (Y) Reading	As Level (ppb)	Ihara (Y) Reading	As Level (ppb)	Ihara (Y) Reading	As Level (ppb)	Ihara (Y) Reading	As Level (ppb)
0.00	>BDL	0.15	<0.9	0.30	2.3	0.45	4.5	0.60	9.2	0.75	26	0.90	>30
0.01	BDL	0.16	<1.0	0.31	2.4	0.46	4.7	0.61	9.8	0.76	28	0.91	>30
0.02	BDL	0.17	1.0	0.32	2.5	0.47	4.9	0.62	10.5	0.77	30	0.92	>30
0.03	BDL	0.18	1.1	0.33	2.6	0.48	5.2	0.63	11	0.78	>30	0.93	>30
0.04	BDL	0.19	1.2	0.34	2.7	0.49	5.5	0.64	12	0.79	>30	0.94	>30
0.05	BDL	0.20	1.3	0.35	2.8	0.50	5.8	0.65	13	0.80	>30	0.95	>30
0.06	BDL	0.21	1.4	0.36	2.9	0.51	6.1	0.66	14	0.81	>30	0.96	>30
0.07	BDL	0.22	1.5	0.37	3.0	0.52	6.4	0.67	15	0.82	>30	0.97	>30
0.08	BDL	0.23	1.6	0.38	3.2	0.53	6.7	0.68	16	0.83	>30	0.98	>30
0.09	BDL	0.24	1.7	0.39	3.3	0.54	7.0	0.69	18	0.84	>30	0.99	>30
0.10	BDL	0.25	1.8	0.40	3.5	0.55	7.3	0.70	20	0.85	>30	1.00	>30
0.11	<0.5	0.26	1.9	0.41	3.7	0.56	7.6	0.71	21	0.86	>30	----	----
0.12	<0.6	0.27	2.0	0.42	3.9	0.57	7.9	0.72	23	0.87	>30		
0.13	<0.7	0.28	2.1	0.43	4.0	0.58	8.3	0.73	24	0.88	>30		
0.14	<0.8	0.29	2.2	0.44	4.2	0.59	8.7	0.74	25	0.89	>30		

MSDS 1

Material Safety Data Sheet

Section 1 Chemical Identification

Catalog # / Description: Part Number 481196-D
Name: First Reagent

Section 2 Composition / Information on Ingredients

CAS#: 87-69-4	L-Tartaric Acid	98.7%
CAS#: 7720-78-7	Iron (II) Sulfate • 7H ₂ O	0.7%
CAS#: 10101-97-0	Nickel (II) Sulfate • 6H ₂ O	0.6%

Section 3 Hazards Identification

Precautionary Statements:

- May be irritating to eyes and nasal passages.
- Low toxicity orally, moderately toxicity intravenously.
- Tartaric Acid is reported to have an oral rabbit LD50 at 5000 mg/kg, and a dermal rat LD50 at 485 mg/kg.

Tartaric Acid Reagent has minimal toxicological effect.

However, inhalation may cause irritation of respiratory tract; ingestion in large amounts may cause

gastrointestinal upset; skin or eye contact may cause

mild irritation; prolonged exposure may cause allergic reaction. Wash hands after use.

- Iron (II) Sulfate is harmful if swallowed or inhaled.

Causes irritation to skin, eyes, and respiratory tract.

Affects the liver. Oral mouse LD50: 1520 mg/kg.

- Nickel Sulfate is toxic. Harmful if swallowed. Possible risk of irreversible effects. May cause sensitization by inhalation and skin contact. Possible carcinogen.

Toxicity data: oral rat LD50: 264 mg/kg.

Section 4 First-Aid Measures

• If swallowed, wash out mouth with water. Call a physician or the Poison Control Center as a precaution.

- In case of skin contact, flush with copious amounts of water for at least 15 minutes.

• In case of contact with eyes, flush with copious amounts of water for at least 15 minutes.

- If inhaled, remove to fresh air. If breathing is difficult, give oxygen and seek medical advice.

Section 5 Fire Fighting Measures

Not Applicable since the amount of First Reagent per kit is negligible.

Section 6 Exposure Controls / Personal Protection

Do not expose to eyes, skin, or clothing. Keep away from children and pets. Wash hands thoroughly after handling. Maintain general hygienic practices when using this product.

Section 7 Physical and Chemical Properties

Appearance and Odor:

- Solid/semi-solid, white powder. Soluble in water.

Physical Properties:

- | | |
|---------------------|----------------|
| • Melting Point: | Not Applicable |
| • Vapor Pressure: | Not Applicable |
| • Specific Gravity: | Not Applicable |
| • Vapor Density: | Not Applicable |

Stability:

- Stable when stored under proper conditions.

Hazardous Polymerization:

- Will not occur.

Incompatibilities:

- Reaction with silver, zinc, aluminum in the presence of water or moisture will release explosive Hydrogen gas.

Section 8 Toxicological Information

Acute Effects:

- Do not breathe dust! Avoid contact with eyes, skin, and clothing. Avoid prolonged or repeated exposure.

Section 9 Other Information

The above information is believed to be correct but does not purport to be all-inclusive and shall be used ONLY as a guide. Keep away from children and pets. Store in a dry, cool place. Keep container tightly closed.

MSDS 2

Material Safety Data Sheet

Section 1 Chemical Identification

Catalog # / Description: Part Number 481196-E
Name: Second Reagent

Section 2 Composition / Information on Ingredients

CAS#	10058-23-8	Potassium Peroxymonosulfate	43%
CAS#	7646-93-7	Potassium Bisulfate	23%
CAS#	7778-80-5	Potassium Sulfate	29%
CAS#	7727-21-1	Potassium Peroxydisulfate	3%
CAS#	546-93-0	Magnesium Carbonate	2%

Comments: NOTE: CAS# for mixture is 70693-62-8

Section 3 Hazards Identification

Emergency Overview:

- Physical Appearance: White, granular material
- Immediate Concerns: DANGER. CORROSIVE. Causes

skin and eye damage. Wear goggles or face shield and rubber gloves when handling. May be fatal if swallowed. Irritating to nose and throat. Avoid inhalation or dust. Remove and wash contaminated clothing before reuse.

Potential Health Effects:

- Eyes: DANGER. Corrosive. Causes eye damage. Do not get in eyes.

Section 4 First-Aid Measures

EYES: If contact with eyes occurs: Immediately flush with cold water for at least 15 minutes. Then get immediate medical attention. SKIN: If contact with skin: Rinse off excess chemical and flush skin with cold water for at least 15 minutes. If skin irritation develops, seek medical attention.

INGESTION: If swallowed: Do not induce vomiting. Drink 1-2 glasses of water to dilute the stomach contents. Never give anything by mouth to an unconscious person. Call a physician immediately.

INHALATION: If inhaled: Remove to fresh air. If breathing is difficult, have trained person administer oxygen. If not breathing, give artificial respiration. Call a physician immediately.

Section 5 Fire Fighting Measures

- This product is not flammable or combustible.
- Will release oxygen when heated, intensifying a fire.

Acidic mist may be present.

- Exercise caution when fighting any chemical fire.
- Extinguishing Media: Water

Section 6 Exposure Controls / Personal Protection

Do not expose to eyes, skin, or clothing. Keep away from children and pets. Wash hands thoroughly after handling. Maintain general hygienic practices when using this product.

Section 7 Physical and Chemical Properties

Appearance and Odor:

- Solid. Granular, free-flowing solid. White.
- Odorless

Physical Properties:

- | | |
|---------------------|----------------|
| • Melting Point: | Not Applicable |
| • Vapor Pressure: | Not Volatile |
| • Specific Gravity: | 1.1 to 1.4 |
| • Vapor Density: | Not Volatile |

Stability:

- Stable when stored under proper conditions.

Hazardous Polymerization:

- Will not occur.

Incompatibilities:

- Mixing with compounds containing halides or active halogens can cause release of the respective halogens if moisture is present. Mixing with cyanides can cause release of hydrogen cyanide gas. Mixing with heavy metal salts such as those of cobalt, nickel, copper, or manganese can cause decomposition with release of oxygen and heat.

Section 8 Toxicological Information

Acute Effects:

- | | |
|--------------------|--------------------------|
| • Skin Absorption: | >11,000 mg/kg in rabbits |
| • Oral LD50: | 2,000 mg/kg (rat) |
| • Inhalation LC50: | >5 mg/l (rats) (4-hour) |

Section 9 Other Information

The above information is believed to be correct but does not purport to be all-inclusive and shall be used ONLY as a guide. Keep away from children and pets.

MSDS 3 Material Safety Data Sheet

Section 1 Chemical Identification

Catalog # / Description: Part Number 481196-F
Name: Third Reagent

Section 2 Composition / Information on Ingredients

CAS #: 7440-66-6
Chemical Name: Zinc >99%
Synonyms:

- Blue powder, granular zinc, zinc dust, zinc powder

Section 3 Hazards Identification

Precautionary Statements:

- Flammable solid. This material, like many powders, is capable of causing a dust explosion.
- If inhaled, remove to fresh air. If breathing is difficult, give oxygen and seek medical advice.

Section 4 First-Aid Measures

- If swallowed, wash out mouth with water. Call a physician or the Poison Control Center.
- In case of skin contact, flush with copious amounts of water for at least 2 minutes. Remove contaminated clothing and shoes.
- In case of contact with eyes, flush with copious amounts of water for at least 5 minutes. Call a physician.
- If inhaled, remove to fresh air. If breathing is difficult, give oxygen and seek medical advice.

Section 5 Fire Fighting Measures

Fire/Explosion Hazard:

- Dust may form a flammable/explosive mixture with air. May form explosive mixture with oxidizers.
- Extinguishing Media:
- Sand or inert dry powder. Do not use water.

Section 6 Exposure Controls / Personal Protection

Do not get in eyes, on skin, on clothing. Keep away from children and pets. Wash hands thoroughly after handling. Use with adequate ventilation. Maintain general hygienic practices when using this product.

Section 7 Physical and Chemical Properties

Appearance and Odor:
Solid bluish-gray powder

Physical Properties:

- Melting Point: 419°C
- Vapor Pressure: Not Applicable
- Specific Gravity: 7,14
- Vapor Density: Not Applicable

Stability:

- Stable when stored dried and at room temperature.

Hazardous Polymerization:

- Will not occur.

Section 8 Toxicological Information

- Skin and eye irritation may result from intermittent exposure.
- Avoid creating dust. DO NOT breathe dust.

Section 9 Other Information

The above information is believed to be correct but does not purport to be all-inclusive and shall be used ONLY as a guide. Dispose of empty bottle as normal trash. Keep away from children and pets.

MSDS 4 Material Safety Data Sheet

Section 1 Chemical Identification

Catalog # / Description: Part Number 481196-G
Name: Arsenic Quick™ Testing Pad

Section 2 Composition / Information on Ingredients

CAS #: 7789-47-1
Synonyms:

- Toxic ingredient is: Mercuric Bromide.

Section 3 Hazards Identification

Precautionary Statements:

- Toxic poison is contained in testing pad (about 1mg / strip).
- Mercuric Bromide is reported to have an oral rat LD50 at 40mg/kg, and a dermal rat LD50 at 100mg/kg.

Section 4 First-Aid Measures

- If swallowed, wash out mouth with water. Call a physician or the Poison Control Center as a precaution.
- In case of skin contact, flush with copious amounts of water for at least 2 minutes. Remove contaminated clothing and shoes.
- In case of contact with eyes, flush with copious amounts of water for at least 5 minutes.
- If inhaled, remove to fresh air. If breathing is difficult, give oxygen and seek medical advice.

Section 5 Fire Fighting Measures

Not Applicable since the amount of Mercury per kit is negligible.

Section 6 Exposure Controls / Personal Protection

Do not expose to eyes, skin, or clothing. Keep away from children and pets. Wash hands thoroughly after handling. Maintain general hygienic practices when using this product.

Section 7 Physical and Chemical Properties

Appearance and Odor:

- Solid/semi-solid, white paper pad (containing Mercuric Bromide) attached to plastic strip.

Physical Properties:

- Melting Point: Not Applicable
- Vapor Pressure: Not Applicable
- Specific Gravity: Not Applicable
- Vapor Density: Not Applicable

Stability:

- Stable when stored under proper conditions.

Hazardous Polymerization:

- Will not occur.

Section 8 Toxicological Information

Acute Effects:

• Each strip contains about 1mg Mercuric Bromide so toxicological effect is minimal because of the amount. However, material is toxic and should be handled carefully to minimize exposure. Place all used test strips into plastic bag labeled "Used Test Strips". Dispose of used strips per environmental and regulatory requirements in your community. Wash hands after use.

Section 9 Other Information

The above information is believed to be correct but does not purport to be all-inclusive and shall be used ONLY as a guide. Dispose of the used test strips as regulations require. Keep away from children and pets.

LETTER FROM THE KIT INVENTOR

Thank you for purchasing our U.S. Patented (# 6,696,300) Arsenic Quick™ II Kit. Our company has trademarked the kits Quick™ because of the short 14 minute time for analysis.

The Drinking Water standard of the US EPA and the World Health Organization (WHO) allows a maximum contaminant level of 10 ppb (µg/L) for Arsenic. The old US EPA level of 50 ppb (µg/L) remains as the maximum contaminant level for many countries in the world.

For several years, Industrial Test Systems, Inc. (ITS) committed a major research & development effort to provide better and safer arsenic test kits. The goal was achieved. The test was made safer by using tartaric acid, instead of strong acids, for the reduction of inorganic arsenic (As³⁺/As⁵⁺) to arsine gas. For these efforts a US Patent was granted for the acceleration of the arsenic detection chemistry by the addition of metal enhancers, iron and nickel salts. This permits Arsenic field tests to be completed faster. The Quick™ II series of kits use a modified Turret cap which allows detection of arsenic below 10 ppb (µg/L). The reduction reactions utilized in all kits are as follows:

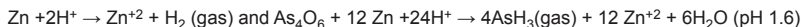

The analysis is performed in a closed reaction bottle (plastic) with an appropriate volume of sample (50 to 500 ml). After the 10 minute reduction reaction, the mercuric bromide strip or testing pad is removed and matched to the color chart or color analyzed by the Quick™ Arsenic Scan instrument. A light yellow to brown color change indicates that arsenic is present. The color intensity is proportionately related to the concentration of arsenic in the sample. NOTE: ITS test kits detect free inorganic arsenic only. ICP-MS methods detect inorganic and organic arsenic. If organic arsenic is present, ITS kit results can be expected to give lower values when compared to ICP-MS results.

Quick™ Arsenic Test Kits Available:

US Patent # 6696300

PRODUCT NAME (PART NUMBER)	NO. OF TESTS		OPTIMUM RANGE* (µg/L)	TYPICAL COLOR CHART DETECTION LEVELS ppb (µg/L)	TYPICAL ACCURACY** OF DUPLICATES USING QUICK™ ARSENIC SCAN	PRICE IN US \$
Arsenic Quick™ Mini Kit (481396-5) <small>(Can also be used for soil analysis.)</small>	5	YES	10 to 200	0, 5, 10, 20, 60, 100, 300, 500, >500, >>500	+/-18 ppb or +/-30%	\$25.99
Arsenic Quick™ II Mini Kit (481303-5)	5	YES	3 to 20	<1, 2, 3, 4, 5, 6, 7, 8, 10, 13, 20, 25, 30, 40, >50, >80, >120, >160	+/-1.2 ppb or +/-16%	\$44.99
Arsenic Low Range Quick™ II Mini Kit (481301-5)	5	YES	1 to 10	<0.5, 1, 1.5, 2, 3, 4, 5, 6, 7, 8, 12, >20, >30, >50	+/-0.8 ppb or +/-14%	\$54.99
Arsenic Ultra-Low Quick™ II (481300-5)	5	YES	0.5 to 6	0, 0.3, 0.7, 1.0, 1.5, 2, 2.5, 3, 3.5, 4, 5, 6, 8, 10, 13, 20, >20	+/-0.4 ppb or +/-12%	\$69.99
Arsenic Quick™ Kit (481396) <small>(Can also be used for soil analysis.)</small>	100	YES	10 to 200	5, 10, 20, 30, 40, 50, 60, 80, 100, 150, 200, 250, 300, 400, 500, >500	+/-18 ppb or +/-30%	\$169.99
Arsenic Low Range Quick™ (481297-I)	50	YES	7 to 80	<2, 4, 10, 15, 20, 25, 30, 40, 50, 60, 70, 80, 100, >150, >300	+/-8 ppb or +/-25%	\$179.99
Arsenic Quick™ II (481303)	50	YES	3 to 20	<1, 2, 3, 4, 5, 6, 7, 8, 10, 13, 20, 25, 30, 40, >50, >80, >120, >160	+/-1.2 ppb or +/-16%	\$219.99
Arsenic Low Range Quick™ II (481301)	50	YES	1 to 10	<0.5, 1, 1.5, 2, 3, 4, 5, 6, 7, 8, 12, >20, >30, >50	+/-0.8 ppb or +/-14%	\$349.99
Arsenic Ultra-Low Quick™ II (481300)	25	YES	0.5 to 6	0, 0.3, 0.7, 1.0, 1.5, 2, 2.5, 3, 3.5, 4, 5, 6, 8, 10, 13, 20, >20	+/-0.4 ppb or +/-12%	\$299.99
Quick™ Arsenic Scan Instrument (481305)	1 meter	YES	N/A	0.01 to >1.00 color density ppb (µg/L) (as low as 0.2 ppb (µg/L) arsenic)	(see above)	\$1,599.99

Information on the performance characteristics of Quick™ can be found at www.epa.gov/etv, or call ITS at 1-800-861-9712 for a copy of the ETV verification report. The use of the ETV® Name or Logo does not imply approval or certification of this product nor does it make any explicit or implied warranties or guarantees as to product performance.

*Range can be expanded by diluting the sample with Arsenic-free water.

**As with any test, actual results will fall within a range around the actual value. The Typical Accuracy listed is from data generated by a technician in our lab using the Quick™ Arsenic Scan instrument measuring interference-free aqueous arsenic standards. Kit expected accuracy is the larger of the two values listed. (Example using Quick™: If the mean is 40 ppb, then the typical accuracy is +/-18 ppb which is larger than +/-12 ppb (40 ppb X 30%).

Where precision is important, ITS recommends that you run the water sample in duplicate, since the typical color matching is within one color block. For best precision consider the purchase of our Quick™ Arsenic Scan instrument. This unit is ideal for use with all test kits. Please contact our sales department at 803-329-9712 for more information or to order the Quick™ Arsenic Scan instrument.

Typical shelf life of kits is over 12 months. The kit includes First Reagent (Tartaric acid with iron and nickel salts); Second Reagent (MPS, an oxidizer); Third Reagent (zinc dust); and mercuric bromide strips, which contains about 1mg mercury per strip. After use, the strips should be discarded according to local environmental regulations. Valuable safety information about the kit is in the MSDS literature. As a safeguard to minimize the operator's exposure to arsine and hydrogen gas, please run all tests in a well-ventilated area away from open flames and other sources of ignition. Arsine gas is highly toxic; and this precaution becomes more urgent if the water sample has high arsenic levels.

Cordially yours,

Ivars Jaunakais, Analytical Chemist
email: Ivars@sensafe.com